

**TOP-QUALITY
PNEUMATIC ACTUATOR**



SUNSHINE-ITORK





PDS Series Pneumatic Actuators are designed using Scotch-Yoke technology from PDS 45 to the largest of PDS 200. Scotch-Yoke technology is well known to all users as the most suitable actuator mechanism for valve and damper operation as it produces higher torque at both end positions.

Specification of PDS actuators follow international standards for faster and easier mounting of accessories like Solenoid valves, Limit switches, Positioners etc.

Ranges available from 10Nm to 4000Nm through double acting, and 5Nm to 1900Nm through spring return.

Maximum operating temperature is $-20^{\circ}\text{C} \sim 80^{\circ}\text{C}$ as standard (For higher and lower temperature applications please consult manufacturer before placing order).

Mounting dimensions follow ISO5211, DIN3337, NAMUR, VDI/VDE3845 standards,

The drive shafts come in various sizes with double square shaped female bore for accomodating valve shaft.

Spring package is pre-compressed for increased safety.

Extremely long service life and reliable performance.

SUSIN I-TORK also provides ITS series limit switch boxes (weather proof, explosion proof), solenoid valves, positioners for modulating services and other pneumatic components.

Side hand-wheel and de-clutchable gear box for manual operation are also options in the SUSIN I-TORK product range.



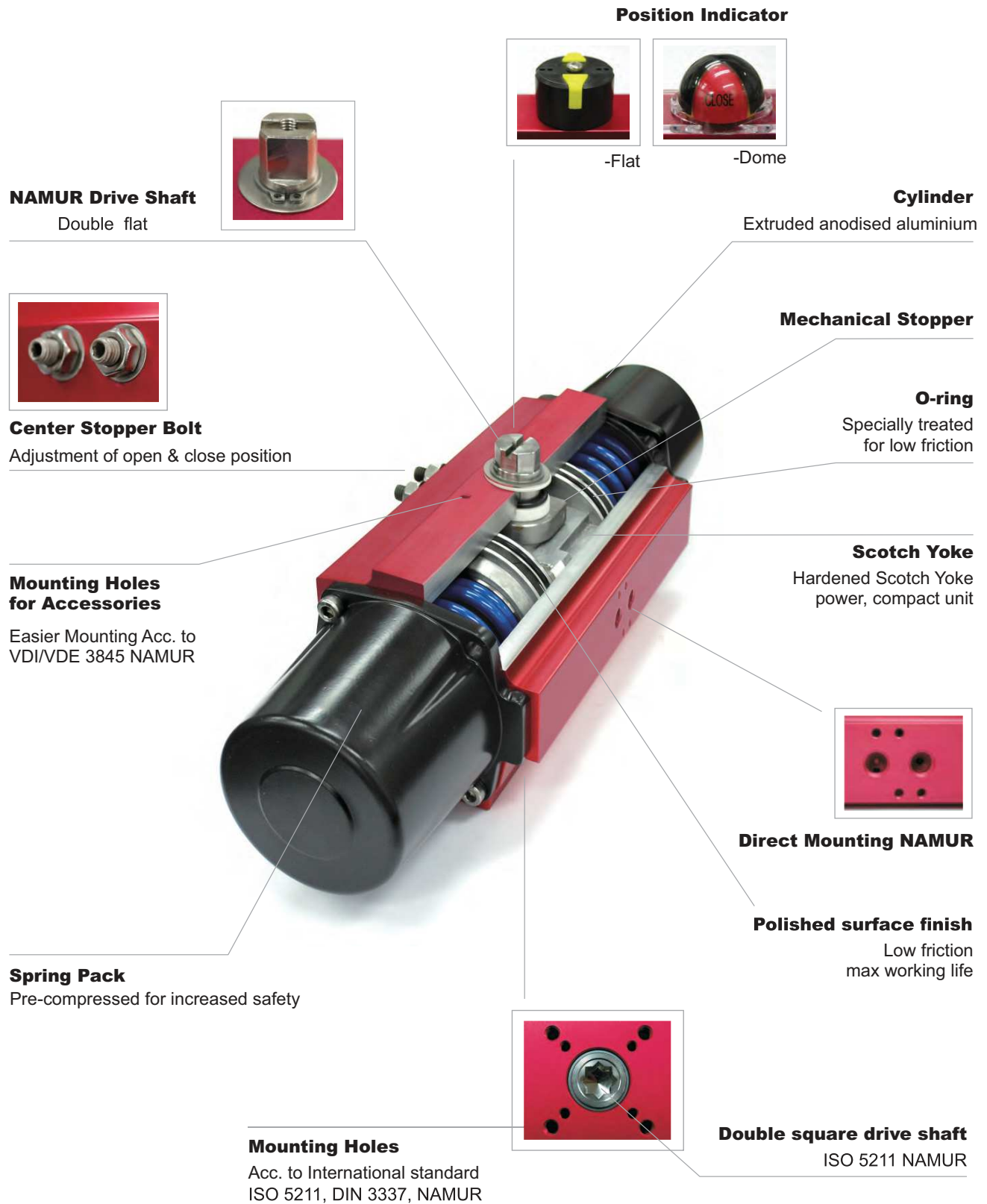



energy ahead...

FEATURES AND ADVANTAGE



Advantage (Scotch Yoke)

The SUSIN I-TORK actuators provide increased torque at the open and close position, this closely matches the required torque for practical valve operation.

- Increased torque at the open and close position.
- Compact design and size
- Extremely long cyclic life
- Adjustable center stopper for both open & close position

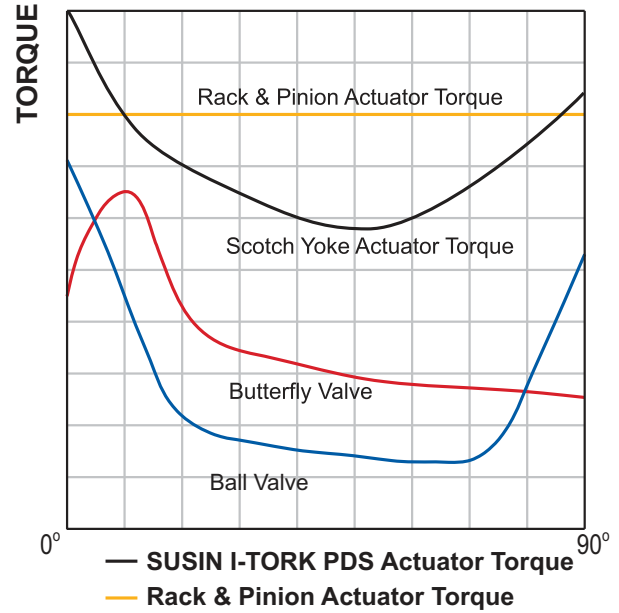

MECHANICAL MOVEMENT & POSITION INSIDE

DOUBLE ACTING

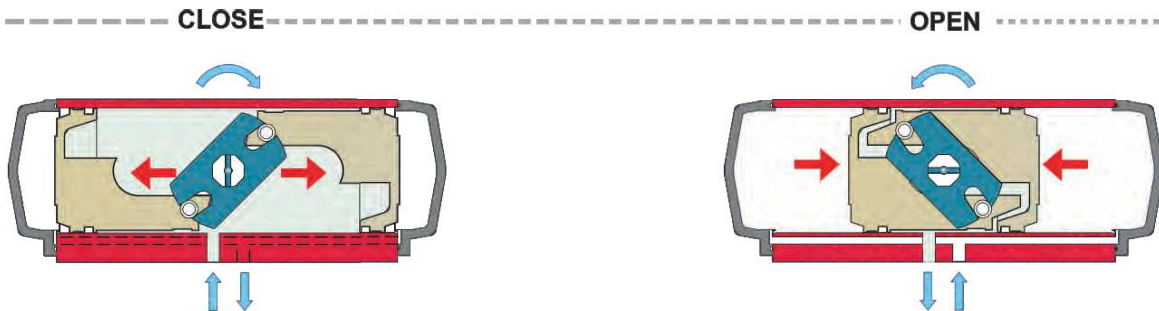

SPRING RETURN

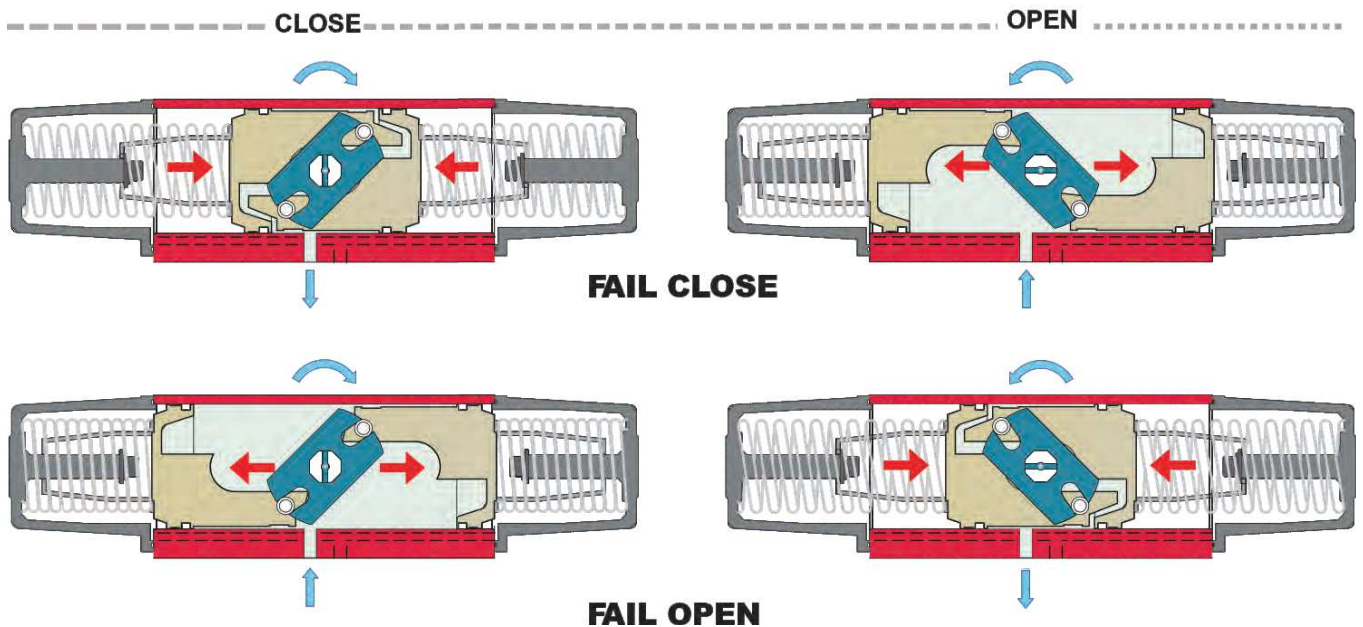

DOUBLE ACTING OUTPUT TORQUE (Nm)

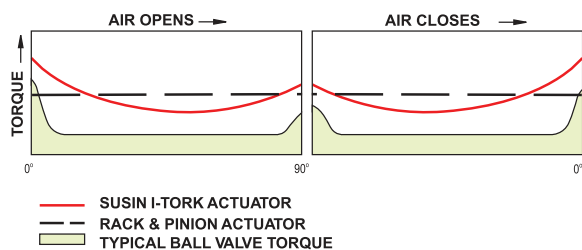

MODEL	Angle	2.8 bar 40 psi	3.5 bar 50 psi	4.2 bar 61 psi	5.5 bar 80 psi	6 bar 87 psi	7 bar 100 psi	8 bar 116 psi	Air Consumption (L, at 5.5 bar)		Operating Time (Sec., at 5.5bar)
									OPEN	CLOSE	
PD45	0°	12	16	20	26	28	34	38			< 0.3
	45°	5	7	9	11	12	14	16	0.12	0.12	
	90°	8	12	15	18	20	23	27			
PD50	0°	27	34	41	54	59	69	79			< 0.3
	45°	12	15	17	23	25	29	33	0.16	0.16	
	90°	19	24	29	38	42	48	55			
PD55	0°	27	45	56	73	80	94	107			< 0.4
	45°	15	18	23	30	33	37	44	0.34	0.34	
	90°	25	32	39	51	57	65	75			
PD70	0°	76	95	114	149	163	190	217			< 0.6
	45°	32	40	48	62	68	79	90	0.46	0.46	
	90°	53	66	78	104	114	133	152			
PD75	0°	112	141	170	223	243	284	324			< 0.9
	45°	47	58	70	93	101	117	134	0.99	0.96	
	90°	78	98	119	155	170	198	226			
PD85	0°	141	176	212	277	302	353	403			< 1.0
	45°	59	74	89	116	127	148	169	0.8	0.8	
	90°	99	123	148	194	212	247	282			
PD100	0°	229	286	343	449	490	571	653			< 2.0
	45°	96	120	144	188	205	239	273	1.32	1.28	
	90°	160	200	240	314	343	400	457			
PD125	0°	438	547	657	860	938	1,095	1,250			< 3.0
	45°	182	228	273	358	390	456	521	2.49	2.42	
	90°	306	383	460	602	657	766	876			
PD160	0°	850	1,062	1,274	1,668	1,820	2,124	2,427			< 5.0
	45°	355	444	533	698	761	888	1,015	4.52	4.61	
	90°	595	744	892	1,168	1,275	1,487	1,700			
PD200	0°	1,622	2,028	2,433	3,187	3,476	4,056	4,635			< 6.0
	45°	679	848	1,018	1,333	1,454	1,697	1,939	9.07	9.21	
	90°	1,136	1,420	1,704	2,231	2,434	2,840	3,245			

*Please be sure to include appropriate torque safety factors and variable service conditions when sizing.



energy ahead...

SPRING RETURN OUTPUT TORQUE (Nm)

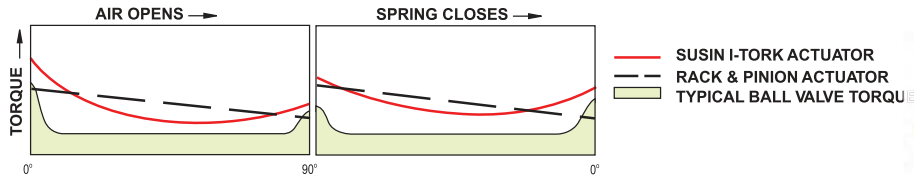

Spring Close

MODEL	Function	Angle	4.2 bar 60 psi	5.5 bar 80 psi	6 bar 87 psi	7 bar 100 psi	Air Consumption (L, at 5.5 bar)	Operating Time (Sec., at 5.5bar)
PS45	Air open	0°	12.0	17.1	18.5	20.5	0.12	< 0.3
		55°	4.0	5.1	5.8	6.4		
		90°	5.1	5.9	6.7	7.6		
	Spring close	90°	9.1	12.3	13.1	15.1		
		35°	4.3	5.5	6.5	7.3		
		0°	7.4	8.7	9.8	11.9		
PS50	Air open	0°	25.6	34.6	37.6	42.5	0.16	< 0.3
		55°	8.3	11.1	12.0	13.4		
		90°	10.0	13.1	14.2	15.4		
	Spring close	90°	18.6	25.0	27.3	32.2		
		35°	9.0	12.0	13.1	15.5		
		0°	15.2	19.9	21.7	25.6		
PS55	Air open	0°	33.1	45.1	48.4	55.2	0.34	< 0.4
		55°	11.0	13.7	14.9	16.9		
		90°	31.7	18.0	19.8	21.9		
	Spring close	90°	23.7	32.1	35.4	41.1		
		35°	11.9	16.2	17.6	20.8		
		0°	20.8	27.2	30.4	36.2		
PS70	Air open	0°	68.3	92.3	98.9	112.3	0.46	< 0.6
		55°	21.9	29.0	31.6	35.4		
		90°	29.0	38.0	41.7	46.2		
	Spring close	90°	49.5	66.7	72.1	84.6		
		35°	25.7	34.3	37.4	43.8		
		0°	43.8	57.2	63.6	74.6		
PS75	Air open	0°	106.4	141.7	154.2	178.1	0.96	< 0.9
		55°	31.5	41.8	45.1	53.2		
		90°	39.7	52.2	56.8	66.5		
	Spring close	90°	77.0	103.2	112.4	127.8		
		35°	37.8	51.2	55.8	64.2		
		0°	59.7	80.9	88.1	100.8		
PS85	Air open	0°	131.9	176.2	187.9	216.7	0.79	< 1.0
		55°	40.1	53.4	57.9	66.9		
		90°	50.4	67.0	72.5	83.9		
	Spring close	90°	95.7	127.8	139.3	159.5		
		35°	48.4	64.5	70.4	80.6		
		0°	76.7	101.9	114.6	131.0		
PS100	Air open	0°	214.6	286.8	311.2	359.6	1.28	< 2.0
		55°	64.7	86.1	93.4	108.4		
		90°	80.5	106.7	115.7	134.9		
	Spring close	90°	156.0	208.7	227.2	259.2		
		35°	78.6	104.9	114.3	130.3		
		0°	123.2	163.5	178.5	203.3		
PS125	Air open	0°	412.5	552.4	601.3	689.3	2.42	< 3.0
		55°	115.9	164.9	189.4	217.2		
		90°	132.3	202.8	247.1	283.4		
	Spring close	90°	320.7	401.1	409.7	471.5		
		35°	158.4	200.9	208.4	240.0		
		0°	234.2	309.8	336.4	388.5		
PS160	Air open	0°	802.5	1,075.6	1,189.6	1,373.0	4.61	< 5.0
		55°	239.6	319.5	341.8	395.8		
		90°	294.8	390.9	401.8	467.1		
	Spring close	90°	584.0	780.8	872.5	997.6		
		35°	292.7	390.2	429.9	491.3		
		0°	452.6	579.9	630.3	718.8		
PS200	Air open	0°	1,561.3	2,079.9	2,272.7	2,603.4	9.21	< 6.0
		55°	452.2	607.9	660.3	747.3		
		90°	536.6	729.5	786.7	877.1		
	Spring close	90°	1,141.7	1,508.2	1,646.9	1,920.1		
		35°	564.3	747.4	813.6	946.8		
		0°	835.6	1,115.9	1,202.8	1,391.4		

*Please be sure to include appropriate safety factors and various service conditions when sizing.

SPRING RETURN OUTPUT TORQUE (Nm)

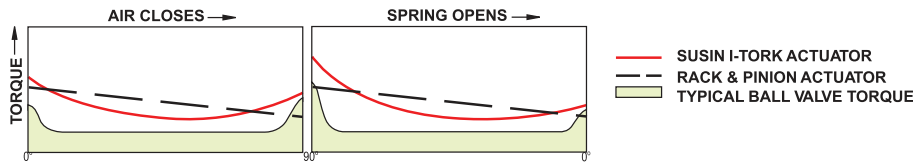

Spring Open

MODEL	Function	Angle	4.2 bar 60 psi	5.5 bar 80 psi	6 bar 87 psi	7 bar 100 psi	Air Consumption (L, at 5.5 bar)	Operating Time (Sec., at 5.5bar)
PS45	Air close	90°	7.9	11.75	12.85	14.5	0.12	< 0.3
		55°	3.9	5.12	5.78	6.24		
		0°	6.87	8.98	9.65	10.78		
	Spring open	0°	12.79	17.32	18.92	22.3		
		35°	3.9	5.1	5.78	6.45		
		90°	4.95	6.34	7.15	8.55		
PS50	Air close	90°	17.9	24.2	26.3	29.8	0.16	< 0.3
		55°	8.3	11.1	12.0	13.4		
		0°	14.3	18.7	20.3	22.0		
	Spring open	0°	26.5	35.7	39.0	46.1		
		35°	8.3	11.0	12.0	14.1		
		90°	10.7	13.9	15.2	17.9		
PS55	Air close	90°	22.78	31.2	33.46	37.8	0.34	< 0.4
		55°	10.65	14.6	15.2	17.65		
		0°	19.8	26.2	28.6	31.7		
	Spring open	0°	34.55	46.57	50.2	58.9		
		35°	10.8	14.4	15.78	17.9		
		90°	14.67	19.45	21.1	25.2		
PS70	Air close	90°	47.8	64.6	69.3	78.6	0.46	< 0.6
		55°	22.7	30.4	32.8	36.9		
		0°	41.4	54.2	59.6	66.0		
	Spring open	0°	70.7	95.3	103.0	120.8		
		35°	22.9	30.3	33.3	39.0		
		90°	30.7	40.1	44.6	52.2		
PS75	Air close	90°	73.85	98.75	107.54	124.8	0.99	< 0.9
		55°	33.1	43.45	48.26	56.3		
		0°	55.95	75.45	81.34	95.13		
	Spring open	0°	110.5	147.1	161.1	183.8		
		35°	32.9	44.15	48.12	55.23		
		90°	42.1	56.35	61.3	69.87		
PS85	Air close	90°	92.4	123.4	131.6	151.7	0.8	< 1.0
		55°	42.3	56.4	61.2	70.6		
		0°	72.0	95.6	103.5	119.8		
	Spring open	0°	136.6	182.5	199.0	227.8		
		35°	42.1	56.1	61.2	70.0		
		90°	53.7	71.4	80.2	91.7		
PS100	Air close	90°	150.3	200.8	217.9	251.8	1.32	< 2.0
		55°	68.5	91.3	99.1	114.8		
		0°	114.9	152.3	165.3	192.7		
	Spring open	0°	222.8	298.0	324.4	370.2		
		35°	68.2	90.9	99.0	112.9		
		90°	86.2	114.5	125.0	142.4		
PS125	Air close	90°	288.8	386.8	421.0	482.6	2.49	< 3.0
		55°	125.6	175.2	191.1	219.1		
		0°	188.9	289.7	352.9	404.8		
	Spring open	0°	458.0	572.9	585.1	673.4		
		35°	135.1	173.5	189.4	218.3		
		90°	164.0	217.0	235.6	272.1		
PS160	Air close	90°	561.9	753.1	832.9	961.4	4.52	< 5.0
		55°	254.5	339.9	367.7	425.3		
		0°	421.0	558.3	573.8	667.0		
	Spring open	0°	834.1	1115.1	1246.1	1424.8		
		35°	255.9	340.6	372.4	425.4		
		90°	316.9	418.6	441.4	503.3		
PS200	Air close	90°	1093.2	1456.4	1591.3	1822.9	9.07	< 6.0
		55°	485.1	650.2	707.6	804.1		
		0°	766.4	1041.9	1123.5	1252.7		
	Spring open	0°	1630.5	2154.0	2352.0	2742.2		
		35°	481.5	639.3	693.9	806.1		
		90°	585.1	781.4	842.2	974.3		

*Please be sure to include appropriate safety factors and various service conditions when sizing.



DIMENSIONS

energy ahead...

DOUBLE ACTING : PD Series

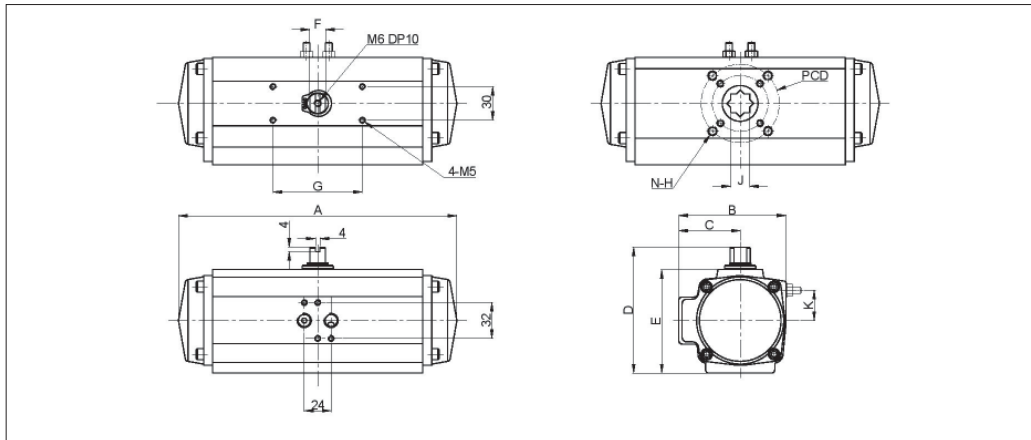

UNIT : mm

MODEL	A	B	C	D	E	F	G	ISO5211	PCD	N-H	J	DP	K	
PD45	159	73	42	91	71	9	80	F03/F05/F07	35/50/70	4-M5/M6	11X11	15	19.5	1.3
PD50	186	73	42	91	71	9	80	F03/F05/F07	35/50/70	4-M5/M6	11X11	15	19.5	1.6
PD55	201	96	55	112	92	14	80	F05/F07	50/70	4-M6/M8	17X17	19	26	2.4
PD70	255	96	55	112	92	14	80	F05/F07	50/70	4-M6/M8	17X17	19	26	3
PD75	270	130	73	150	130	20	80	F07/F10	70/102	4-M8/M10	22X22	30	39.5	6
PD85	300	110	62	130	110	17	80	F05/F07	50/70	4-M6/M8	17X17	24	33	5
PD100	350	130	73	150	130	20	80	F07/F10	70/102	4-M8/M10	22X22	30	39.5	7.5
PD125	412	159	88	182	162	22	80	F10/F12	102/125	4-M10/M12	27X27	35	47.5	11
PD160	510	195	105	240	210	32.8	80/130	F10/F14	102/140	4-M10/M16	36X36	50	62	26
PD200	625	243	130	292	262	40	80/130	F12/F16	125/165	4-M12/M20	46X46	50	77.5	43

Note : Port Size : 1/4" BSP

SPRING RETURN : PS Series

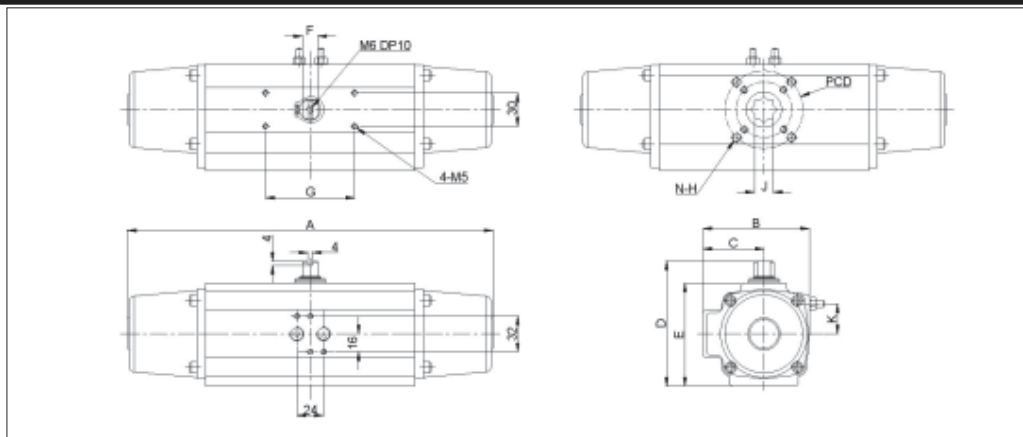

UNIT : mm

MODEL	A	B	C	D	E	F	G	ISO5211	PCD	N-H	J	DP	K	WEIGHT (Kg)
PS45	226	73	42	91	71	9	80	F03/F05/F07	35/50/70	4-M5/M6	11X11	15	19.5	1.5
PS50	255	73	42	91	71	9	80	F03/F05/F07	35/50/70	4-M5/M6	11X11	15	19.5	1.7
PS55	281	96	55	112	92	14	80	F05/F07	50/70	4-M6/M8	17X17	19	26	2.9
PS70	330	96	55	112	92	14	80	F05/F07	50/70	4-M6/M8	17X17	19	26	3.5
PS75	422	130	73	150	130	20	80	F07/F10	70/102	4-M8/M10	22X22	30	39.5	7.5
PS85	423	110	62	130	110	17	80	F05/F07	50/70	4-M6/M8	17X17	24	33	5.5
PS100	499	130	73	150	130	20	80	F07/F10	70/102	4-M8/M10	22X22	30	39.5	10
PS125	629	159	88	182	162	22	80	F10/F12	102/125	4-M10/M12	27X27	35	47.5	18
PS160	744	195	105	240	210	32.8	80/130	F10/F14	102/140	4-M10/M16	36X36	50	62	35.5
PS200	869	243	130	292	262	40	80/130	F12/F16	125/165	4-M12/M20	46X46	50	77.5	73

Note : Port Size : 1/4" BSP

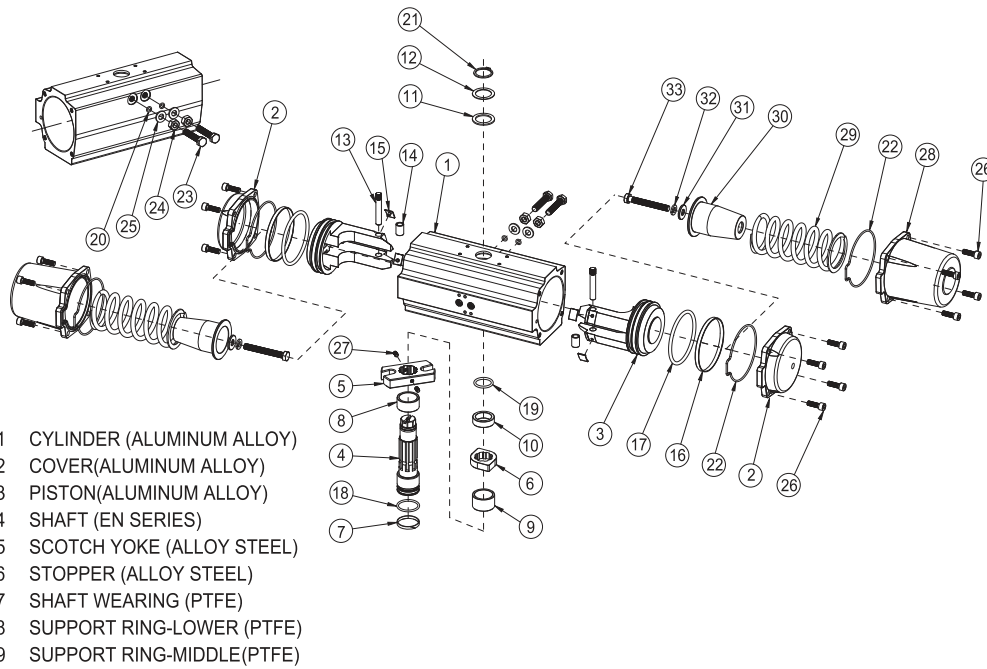

- 1 CYLINDER (ALUMINUM ALLOY)
- 2 COVER(ALUMINUM ALLOY)
- 3 PISTON(ALUMINUM ALLOY)
- 4 SHAFT (EN SERIES)
- 5 SCOTCH YOKE (ALLOY STEEL)
- 6 STOPPER (ALLOY STEEL)
- 7 SHAFT WEARING (PTFE)
- 8 SUPPORT RING-LOWER (PTFE)
- 9 SUPPORT RING-MIDDLE(PTFE)

- 10 SUPPORT RING-UPPER (PTFE)
- 11 THRUST WASHER (PTFE)
- 12 WASHER (SS)
- 13 ROLLER PIN (EN SERIES)
- 14 ROLLER (EN SERIES)
- 15 PISTON GUIDE PAD (PTFE)
- 16 SUPPORT BAND (PTFE)
- 17 O-RING (NBR)
- 18 O-RING (NBR)
- 19 O-RING (NBR)
- 20 O-RING (NBR)
- 21 SNAP RING (SS)
- 22 O-RING (NBR)
- 23 ADJUST BOLT (EN SERIES)
- 24 ADJUST NUT (SS)
- 25 WASHER (SS)
- 26 ALLEN HEAD CAP SCREW (SS)
- 27 SET SCREW (SS)
- 28 SPRING RETURN COVER (ALUMINUM ALLOY)
- 29 SPRING (SPRING STEEL)
- 30 SPRING RETAINER (ALLOY STEEL)
- 31 PLAIN WASHER (SS)
- 32 SPRING WASHER (SS)
- 33 PRE TENSION BOLT (SS)

PD40 (RACK & PINION)

OUTPUT TORQUE

TORQUE (Nm)

PD40	PRESSURE	2.8	3.5	4.2	5.5	6	7	8
	TORQUE	5.6	7	8.4	11	12	14	16

Please be sure to include appropriate safety factors and various service conditions when sizing.

AIR CONSUMPTION (L, at 5.5 bar)

0.04

OPERATING TIME (Sec., at 5.5bar)

< 0.3

Air
Volume
0.04 Litre

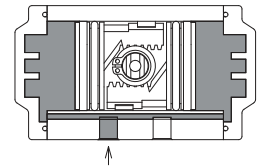

Air
Volume
0.04 Litre

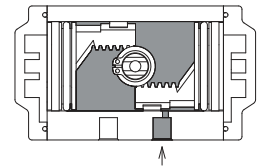

DIMENSIONS

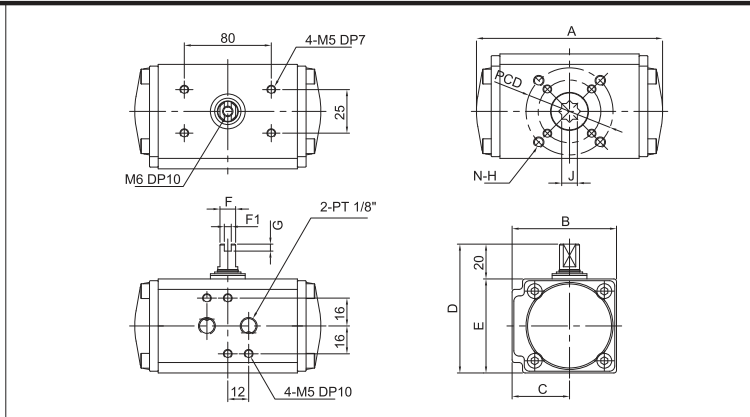

MODEL	A	B	C	D	E	F	F1	G	ISO5211	PCD	N-H	J	DP	WEIGHT
PD40	107	60	33	74	54	9	4	4	F03/F05	35/50	4-M5/M6	9x9	11	1.1



EXPLODED VIEW

energy ahead...

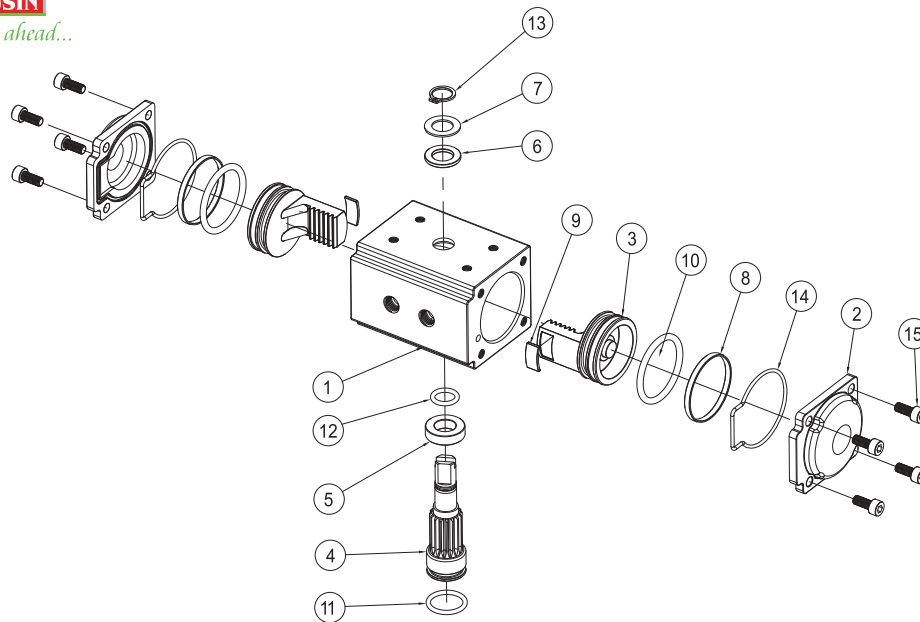

- 1 CYLINDER (ALUMINUM ALLOY)
- 2 COVER (ALUMINUM ALLOY)
- 3 PISTON (ALUMINUM ALLOY)
- 4 SHAFT (EN8)
- 5 SUPPORT RING-UPPER (PTFE)
- 6 THRUST WASHER (PTFE)
- 7 WASHER (SS)
- 8 SUPPORT BAND (PTFE)
- 9 PISTON GUIDE PAD (PTFE)
- 10 O-RING (NBR)
- 11 O-RING (NBR)
- 12 O-RING (NBR)
- 13 SNAP RING (SS)
- 14 O-RING (NBR)
- 15 SUS WRENCH BOLT (SS)

ACCESSORIES

ITS Series Position Monitoring Switch Box

ITS 200 Series (Weather Proof)



SPECIFICATION	STANDARD OPTION
Enclosure	Weather proof IP67, O-ring sealed
Outside coating	Epoxy-Polyester inside and outside
Ambient temperature	-20°C ~ +80°C
Cable entries	2-NPT 1/2", other standard threads
Terminal block	8 nos of terminal strips
Position indicator	Dome type 0°~90°
Mounting bracket	Stainless steel acc. to VDI/VDE 3845, NAMUR standard
Switches(Sensors)	2-SPDT mechanical switch(Form C)

ITS 400 Series (Explosion Proof)

Suitable for valves and actuators in hazardous area applications conforms to EN50014 and 50018, also suitable in Zone 1 and 2

Ex d : IECEx, GOST_R/RTN certified



SPECIFICATION	STANDARD OPTION
Enclosure	Explosion proof Ex d IIC T6, IP67, O-ring sealed
Outside coating	Epoxy-Polyester outside against corrosion
Ambient temperature	-20°C ~ +80°C
Cable entries	2-M20*1.5, other standard threads
Terminal block	8 nos of terminal strips
Position indicator	Dome type 0°~90°
Mounting bracket	Stainless steel acc. to VDI/VDE 3845, NAMUR standard
Switches(Sensors)	2-SPDT mechanical switch(Form C)

ITS 500 Series

Special stainless steel housig (316L or Duplex) for extremely corrosive environmental conditions & for off-shore applications.

Other specifications are shared with the ITS 400 series except for enclosure & coating.

Ex d : IECEx, GOST_R/RTN certified



Electro-Pneumatic Positioner

EPL / EPR (Mechanical Type)



EPL (Linear Type)



EPR (Rotary Type)

FEATURE

- Precise calibration with simple SPAN and ZERO adjustments
- Simple conversion to direct acting or reverse acting
- 1/2 split range available
- Rugged aluminum housing with corrosion-resistant coating
- Stainless steel gauges standard
- Restricted pilot valve orifice kit for small actuators included

*Options available

- Position transmitter (4-20mA output signal)
- Two limit switches (open and close)

SSL / SSR (Electronic Smart Type)

FEATURE

- Auto-calibration for optimum conditions
- Easy operation with four key pads and full text graphical LCD
- Single and double acting actuators
- Pressure regulator built in to eliminate variations in supply air pressure
- Economical energy saving
- Mounting on linear actuators according to IEC 534
- Mounting on rotary actuators according to VDI / VDE 3845

*Options available

- Position transmitter (4-20mA output signal)
- Gauge block with two stainless pressure gauges
- Explosion proof type (Ex d IIB T6, Exia IIC T6)
- HART communication (FSK)



SSL (Linear Type)



SSR (Rotary Type)



IPC

IPC (I/P CONVERTER)

FEATURE

- Pressure regulator built in to eliminate variations in supply air pressure
- Low air consumption due to piezo electric micro-valve
- Explosion proof type (please contact for details)

Solenoid Valve

Our next generation solenoid valves, Specifically engineered to pilot pneumatic process valve actuators, with improved design and added valuable features.

The unique design of the I-Tork solenoid valve redirects the instrument air contained in the pressurized chamber to the actuator's spring chamber during the spring stroke, thus preventing external air from being sucked in.

5/2 function or 3/2 function selectable via 180° turn of the patented rotary sealing plate.

Direct NAMUR standard mounting.



- Weather proof IP65
- NEMA types 1, 2, 3, 3S, 4 and 4X & CE Certified
- ATEX Ex Series
- Ex-Proof Series
- Intrinsically Safe Series
- Standard Series

Electrical

Voltage (+/-10%) : 12VDC & 24 VDC, 24VAC, 120VAC & 240VAC, 50/60Hz
(other voltages are available on request)

Duty Cycle : 100% continuous Service

Construction

Valve Body : Die Cast Aluminum

Sealing Material : NBR and Viton

Inlet Port : 1/4" NPT or G1/4"

Temperature Range : -40°C to 50°C

Pressure : 1.5 to 10 bar

Response : 30 ms (on) 40 ms (off)

Air Flow : Cv>1.1

Media : Lubricated and non lubricated air, Instrument air, Nitrogen

Declutchable Gear Box

Aluminum Housing

MODEL NO	ITG 050	ITG 060	ITG 080	ITG 090	ITG 100	
Output Torque	250 Nm	650 Nm	1000 Nm	2335 Nm	4200 Nm	
Top Flange (ISO 5211)	F07 / F10	F10 / F12	F12 (F14)	F16 (F14)	F16	
Reduction Ratio	40 : 1	45 : 1	48 : 1	60 : 1	83 : 1	
Mechanical Advantage	12.62	14.27	16.31	18.25	25	
Number of Handwheel Turns	10	11.3	12	13	20.75	
Available Max. (Valve Shaft)	Diameter (Ø)	22	32	40	50	95
	Square	17	27	36	46	55
Handwheel Diameter	300	350	450	550	650	
Bottom Flange (ISO 5211)	F07 / F10	F10 / F12	F12 (F14)	F16 (F14)	F16	
Weight	5.5 kg	7.5 kg	13.5 kg	38 kg	76 kg	
Applicable Pneumatic Actuator upto 5.5 bar	PD45/50/55/70/75 PS45/50/55/70	PD85/100 PS75/85/100	PD125 PS125	PD160 PS160	PD200 PS200	



ITG series are rugged, industrial grade manual overrides, manufactured with aluminum housing. All models in this series feature high performance gearings and powder coated finish.

FEATURES

- Cast Aluminum / cast Iron body
- EN8 gears & Internal components
- Declutchable handwheel
- Mounting flanges conforming to ISO5211
- Detachable drive bush
- Mechanical Valve Mounting to release the Air Automatically

CERTIFICATE AND APPROVALS



A joint venture with I-Tork Controls Ltd, Korea



SUSIN I-TORK INDIA PVT LTD.,

4/134-B, Thadagam Road, K.N.G. Pudur Cross, Coimbatore - 641 108. India. Tel : +91 422 240 29 35, 650 54 26
e-mail : info@susinitork.in web : www.susinitork.in

energy ahead...

Subject to reasonable modifications due to technical advances | © SUSIN I-TORK | Printed in India | PDS-CA-1210

